

EMERGENCY LIGHTING INVERTER EMCU K

Emergency lighting inverter for the conversion of LED luminaires

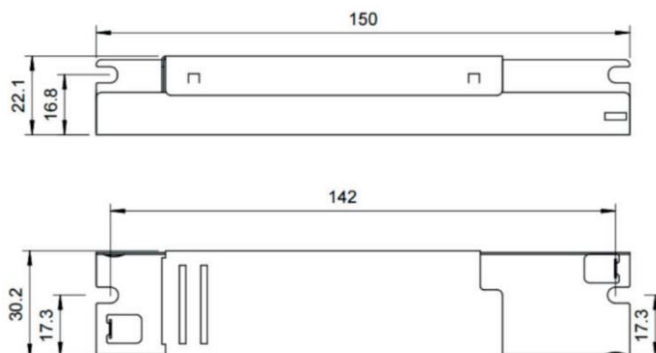

Scope

The emergency lighting inverter EMCU K adds emergency lighting and self-testing functionality to regular LED luminaires. The short and space-saving metal housing fits into a wide range of protection class I luminaires along with the equally compact LFP batteries. A battery regeneration process for capacity optimisation is initiated automatically after commissioning as well as after each battery exchange to allow for the maximum battery lifetime

Technical data

Mains voltage range	220...240 V
Mains frequency	50 / 60 Hz
Output voltage range	10...220 V
Max. output voltage (55 V variant)	60 V
Max. output voltage (105 V variant)	120 V
Max. output voltage (220 V variant)	350 V
Output power in emergency mode	approx. 3 W
Power consumption	max. 5 W / 7 VA
Mains to emergency switchover	< 0,5 s
Max. housing temperature t_c	65 °C
Ambient temperature t_a	5...50 °C
Functional test	random each 8 to 8.25 days
Duration test	4 annual battery discharges
Battery charging time	24h
Protection class	I
Protection type	IP20
Weight	140 g
Dimensions	L 150 x B 30.2 x H 22.1 mm
Hole spacing	142 mm

The maximum LED current in maintained mode, i.e. in active operation, in the LED module must not exceed 2,5 A.

Characteristics

- Self-contained emergency lighting inverter for LED luminaires
- LED forward voltages ranging from 10 to 220V
- 1 h and 3 h emergency durations, others upon request
- Approx. 3 W of constant emergency output power, others on request
- Automatic battery regeneration
- Deep discharge protection
- Selftest conforming to IEC 62034
- Bi-colour LED status indicator
- Compatible with all dimmable and non-dimmable LED drivers
- 3-pin technology: LED module changeover switching and delayed LED driver power switching
- Metal housing
- Suitable for protection class I luminaires
- 60 months warranty

Selftest

- Selftest as per IEC 62034
- Bi-colour battery and LED module status indicator

Batteries

- High-temperature LiFePO₄ battery cells 5 to 60 °C
- Cell size 18650
- Charging time 24 h
- Automatic battery regeneration for capacity optimisation
- EN 62620 (Performance), EN 62133 (Safety)

Safety

- Protection class I
- Protection type IP20
- SELV (55 V and 105 V variants)

Standards

- EN 60598-2-22
- EN 61347-2-7
- EN 61347-2-13
- EN 62384
- EN 62034
- EN 55015
- EN 61000-3-2
- EN 61000-3-3
- EN 61547
- EN 50172 (VDE 0108-100)





Product variants

Specifications	Types		
	EMCU T product variants		
LED forward voltage	min. 10 V max. 55 V	min. 20 V max. 105 V	min. 100 V max. 220 V
Max. output voltage	60 V	120 V	300 V
SELV	touchable LEDs	isolated LEDs	non-SELV
Selftesting variants	EMCU KS 55V	EMCU KS 105V	EMCU KS 220V
Batteries	18650 LiFePO ₄ cells		

Wiring diagram

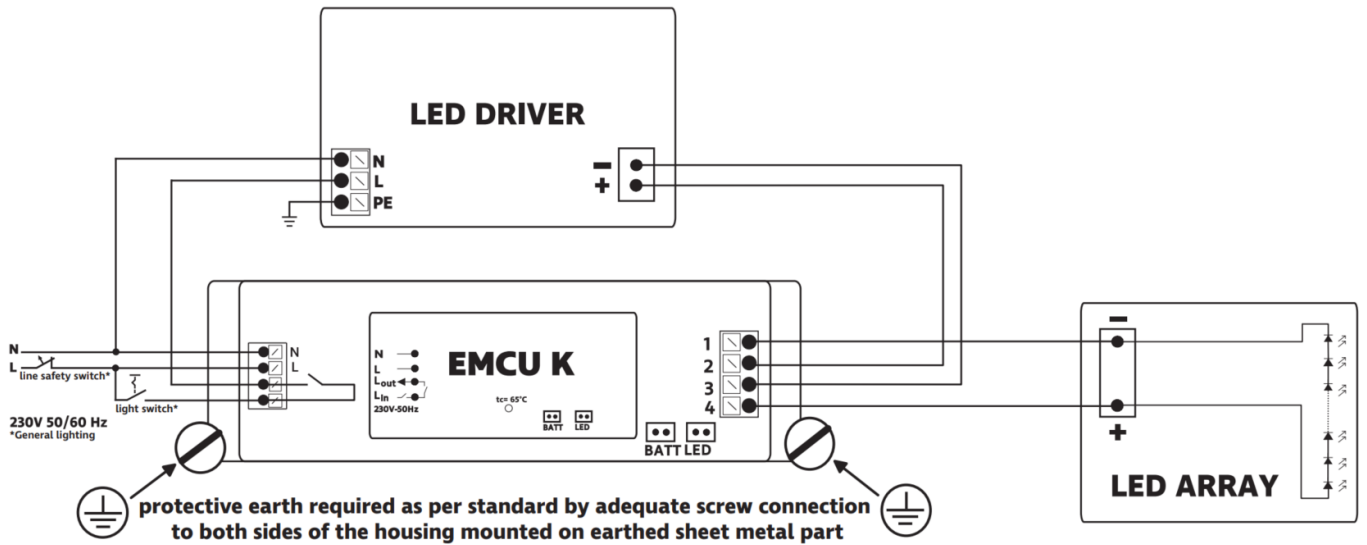

All information supplied without liability. Technical data subject to change without prior notice.